

# Automotive Solutions for Electro-Mobility



# Contents

<b>3</b>	<b>Smart Mobility</b>
<b>4</b>	<b>Electro-Mobility</b>
5	Key Applications
6	Main Traction Inverter
7	On-Board Charger (OBC)
8	48V Start-Stop System
9	Bidirectional DC/DC Converter
10	Battery Management System
11	48V Electric Traction
12	Acoustic Vehicle Alerting System (AVAS)
13	HV Battery Disconnect & Fire-off System
14	Vehicle Control Unit (VCU)
<b>16</b>	<b>Key Technologies</b>
<b>18</b>	<b>Development Tools</b>
18	Product Selectors samples, Evaluation Boards
19	SPC5 Automotive MCU Evaluation Tools
21	AutoDevKit

# Smart Mobility

It is estimated that 80% of all innovations in the automotive industry today are directly or indirectly enabled by electronics. With vehicle functionality improving with every new model this means a continuous increase in the semiconductor content per car.

With over 30 years' experience in automotive electronics, ST is a solid, innovative, and reliable partner with whom to build the future of transportation.

ST's Smart Mobility products and solutions are making driving safer, greener and more connected through the combination of several of our technologies.



**80%**  
of all innovations  
in the automotive  
industry today  
are enabled by  
electronics

## SAFER

Driving is safer thanks to our Advanced Driver Assistance Systems (ADAS) – vision processing, radar, imaging and sensors, as well as our adaptive lighting systems, user display and monitoring technologies.

## GREENER

Driving is greener with our automotive processors for engine management units, engine management systems, high-efficiency smart power electronics at the heart of all automotive sub-systems and devices for hybrid and electric vehicle applications.

## MORE CONNECTED

And vehicles are more connected using our infotainment-system and telematics processors and sensors, as well as our radio tuners and amplifiers, positioning technologies, and secure car-to-car and car-to-infrastructure (V2X) connectivity solutions.

ST supports a wide range of automotive applications, from Powertrain for ICE, Chassis and Safety, Body and Convenience to Telematics and Infotainment, paving the way to the new era of car electrification, advanced driving systems and secure car connectivity.

# Electro-Mobility



**ST**  
provides  
leading-edge  
solutions for  
hybrid (HEV), and  
battery electric  
vehicles (BEV)

The electrification of vehicles is rapidly increasing, driven by the availability of higher performance and more cost-effective battery technologies, and improved mileage as well as ecological awareness, and government incentives and regulation.

ST provides leading-edge solutions for hybrid (HEV), and battery electric vehicles (BEV) based upon proven and innovative technologies and backed up with our extensive power management experience.

Best-in-class silicon and SiC (Silicon Carbide) MOSFETs and diodes, IGBTs, protection components, isolated gate drivers and microcontrollers make up an unrivalled offer for electric vehicle power management. They are available as discrete components, or as part of dedicated system solutions, all in compliance with the AEC-Q100 and AEC-Q101 standards.

Whether you are looking for the cost-effective, yet emission-reducing first step on the electrification ladder with solutions for 48V systems for mild hybrids, or for the traction inverter, battery management system and on-board charger for a fully electric vehicle ST has the products you need.

## KEY APPLICATIONS

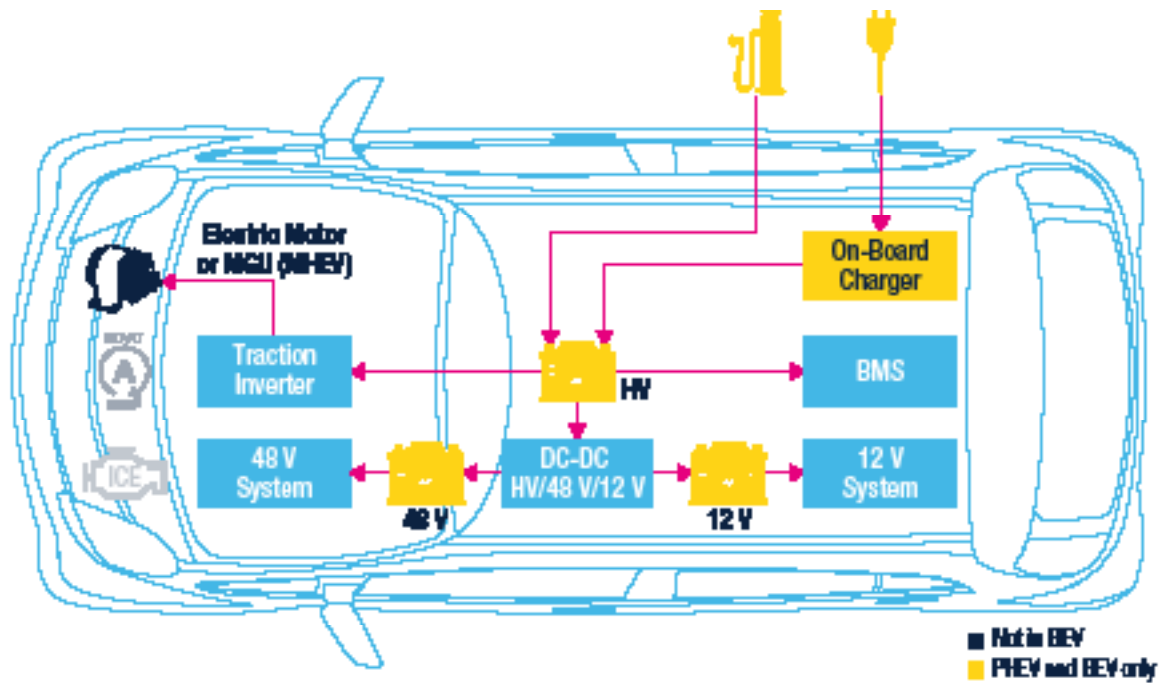

## SOLUTIONS

ST's key products and solutions for Electro-Mobility applications include:

SiC MOSFETs and Diodes	Transceivers	Signal Conditioning	Power Management	32-bit Automotive Microcontrollers
Power MOSFETs and IGBTs	Power Diodes and Thyristors	EOS and ESD Protection	BCD Integrated and Isolated Drivers	

HW & SW Development Tools – Sample Kits, Evaluation Kits, Product Selectors



### FIND OUT MORE

[www.st.com/electro-mobility](http://www.st.com/electro-mobility)  
 Battery Management System (BMS)  
 DC-DC Converter  
 Electric Traction (Main Inverter)  
 Mild Hybrid 48V Systems

On Board Charger (OBC)  
 Acoustic Vehicle Alerting System (AVAS)  
 HV Battery Disconnect & Fire-off System  
 Vehicle Control Unit (VCU)

## MAIN TRACTION INVERTER

The traction inverter converts energy from the vehicle's battery to drive the motors in the drivetrain. This key component has a direct impact on a vehicle's road performance, driving range and reliability, which also depends on the inverter's weight and size.

Subject to intense heat and vibration of the automotive environment, these inverters must be able to handle high power and currents along with associated electro-magnetic compatibility (EMC) challenges. Fail-safe operation needs to be assured to ensure reliability and safety for the driver and passengers.

To help developers increase the inverter's power efficiency and reduce its size and weight, ST has a wide offer of discrete semiconductors including AEC-Q101 qualified silicon and silicon-carbide (SiC) MOSFETs and diodes as well as IGBTs. These are complemented by AEC-Q100 qualified galvanically isolated IGBT and MOSFET gate drivers and SPC5 32-bit automotive microcontrollers for implementing scalable, cost-effective and energy-efficient solutions.

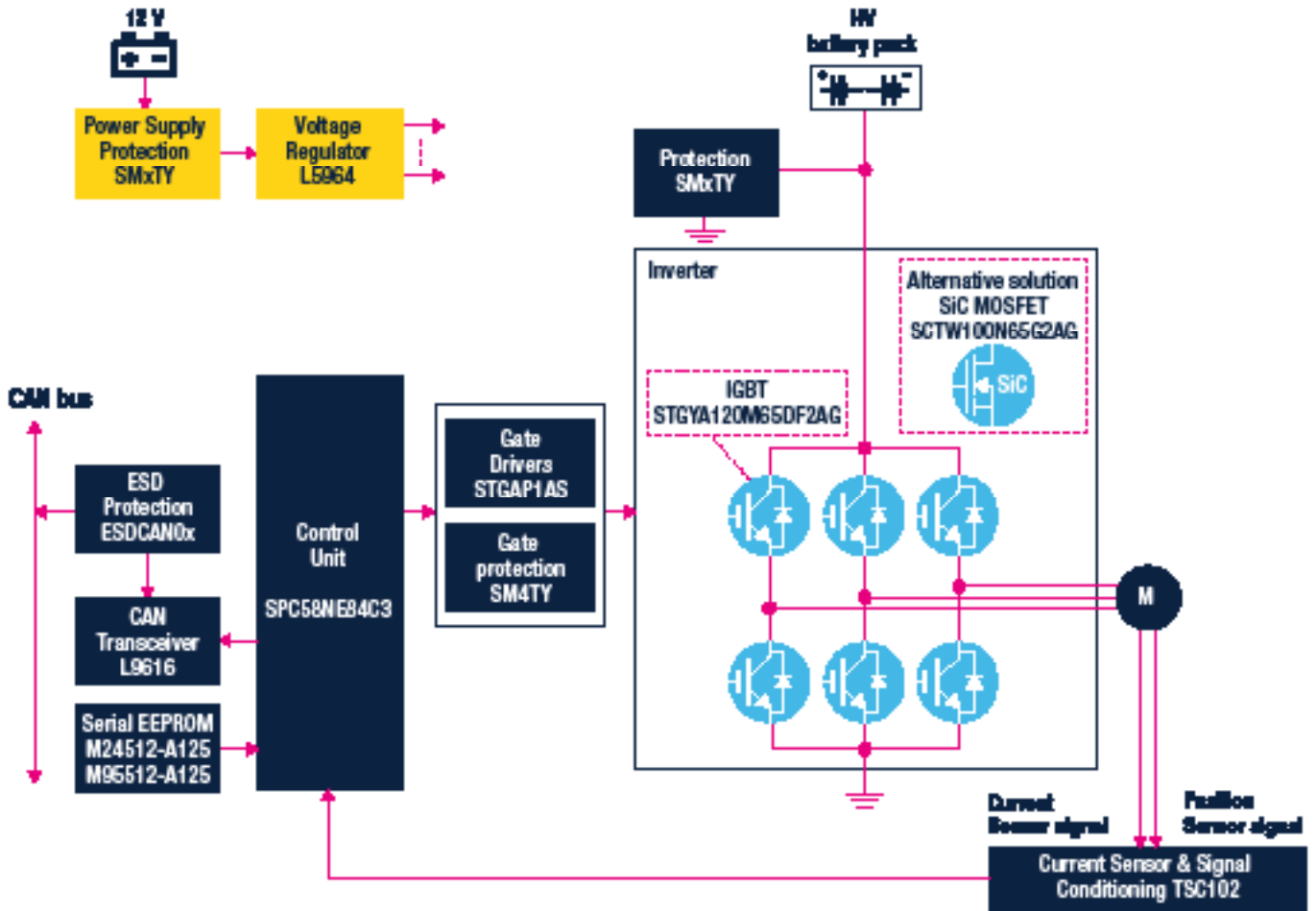

**FIND OUT MORE**

[www.st.com/main-inverter-electric-traction](http://www.st.com/main-inverter-electric-traction)



## ON-BOARD CHARGER (OBC)

At the heart of any electric (EV) or plug-in hybrid (HEV) vehicle lies the high-voltage (200 to 800 V<sub>DC</sub>) battery and its associated charging system. The on-board charger (OBC) provides the means to recharge the battery from the AC mains either at home or from outlets found in private or public charging stations.

From a 3.6 kW single-phase to a 22 kW three-phase high-power converter, today's OBCs must have the highest possible efficiency and reliability to ensure rapid charging times as well as meet the limited space and weight requirements.

ST has a wide offer of discrete semiconductors including AEC-Q100 qualified silicon and silicon-carbide (SiC) MOSFETs and diodes as well as IGBTs. These are complemented by AEC-Q100 qualified galvanically isolated IGBT and MOSFET gate drivers and SPC5 32-bit automotive microcontrollers for implementing these challenging converters.

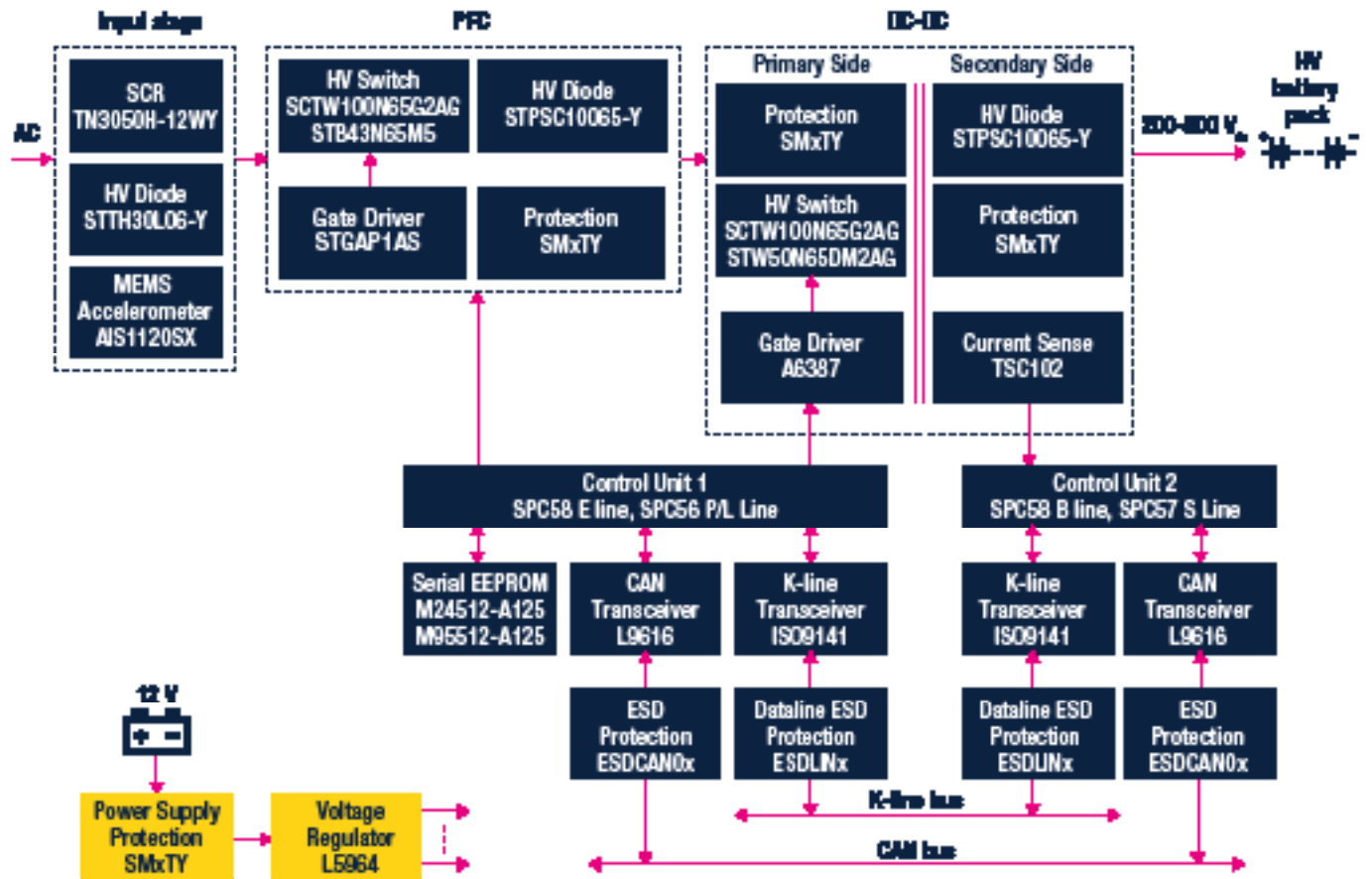

FIND OUT MORE

[www.st.com/on-board-charger](http://www.st.com/on-board-charger)

## 48V START-STOP SYSTEM

A Start-Stop system automatically shuts down and restarts the internal combustion engine to reduce the amount of idle time, thereby improving fuel economy and reducing CO<sub>2</sub> emissions. This is especially useful in urban traffic environments where vehicles can spend significant amounts of time in traffic.

This requires power electronics that can handle high current during cranking and ensure reliability during engine cycles switching on/off at high temperatures.

ST's solutions include silicon power MOSFETs, protections, gate drivers and microcontrollers, in accordance to AEC-Q100 and AEC-Q101 standards.

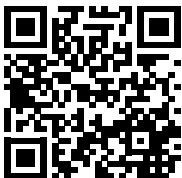
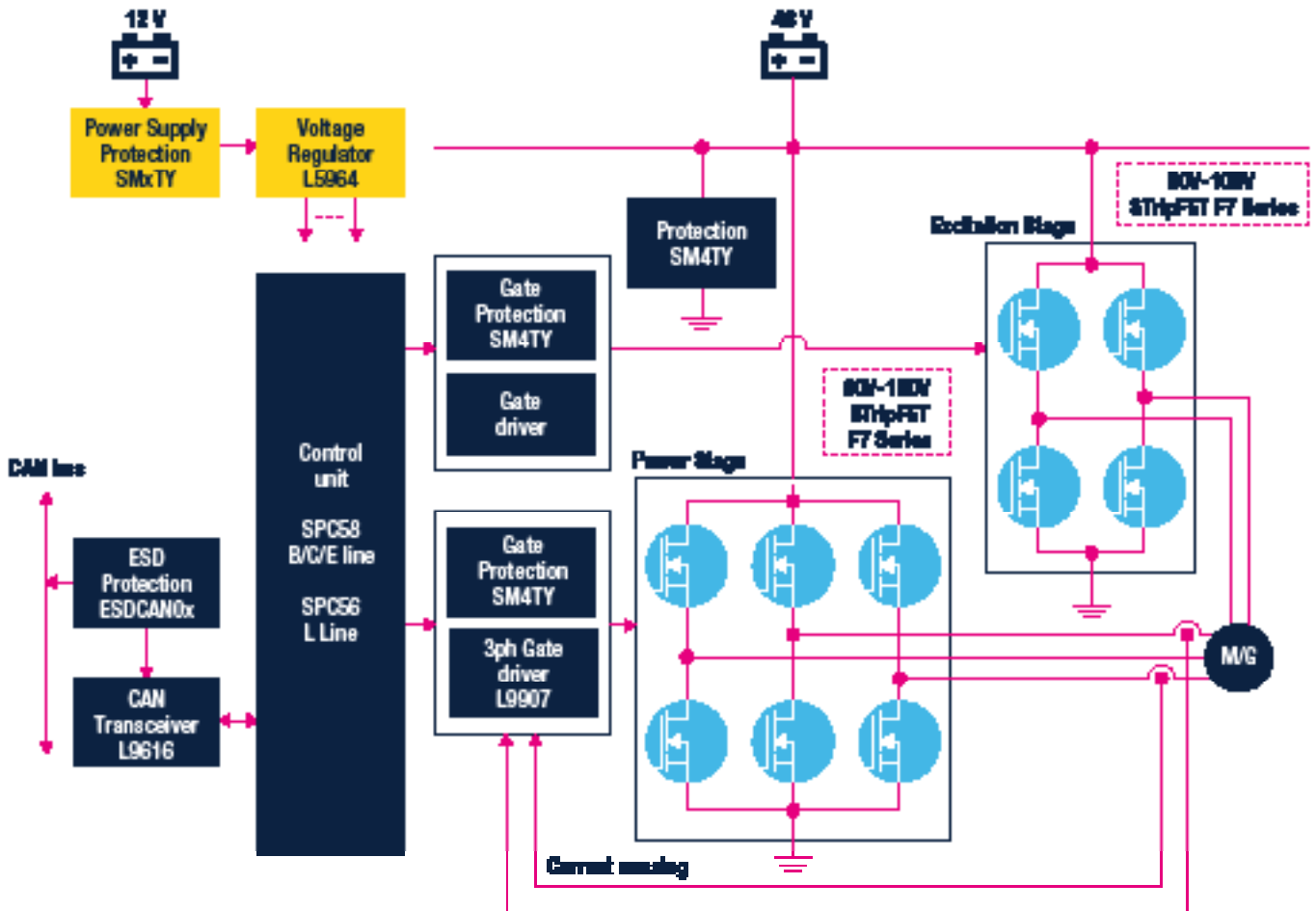

**FIND OUT MORE**

[www.st.com/48v-start-stop-system](http://www.st.com/48v-start-stop-system)



## BIDIRECTIONAL DC/DC CONVERTER

Electric vehicles (EV) use two different power systems; an high-voltage battery (200 to 800 V<sub>DC</sub>) for traction and a low-voltage (12/48V) one for supplying all the electric appliances in the vehicle. Traditionally, the low-voltage battery was charged from the alternator, but in today's vehicles it gets its power from the high-voltage battery pack. However, in specific electric car architectures, this low-voltage battery should be ready to help recharge the high-voltage battery pack in order to provide energy for cranking the car. This means that the on-board DC-DC converter must be bi-directional and very efficient as well as highly reliable in order to run the complex control algorithms needed to ensure an energy-efficient solution.

ST has a wide offer of discrete semiconductors including AEC-Q101 qualified silicon and silicon-carbide (SiC) MOSFETs and diodes as well as IGBTs. These are complemented by AEC-Q100 qualified galvanically isolated IGBT and MOSFET gate drivers and SPC5 32-bit automotive microcontrollers to enable scalable, cost-effective and energy-efficient solutions for implementing these challenging converters.

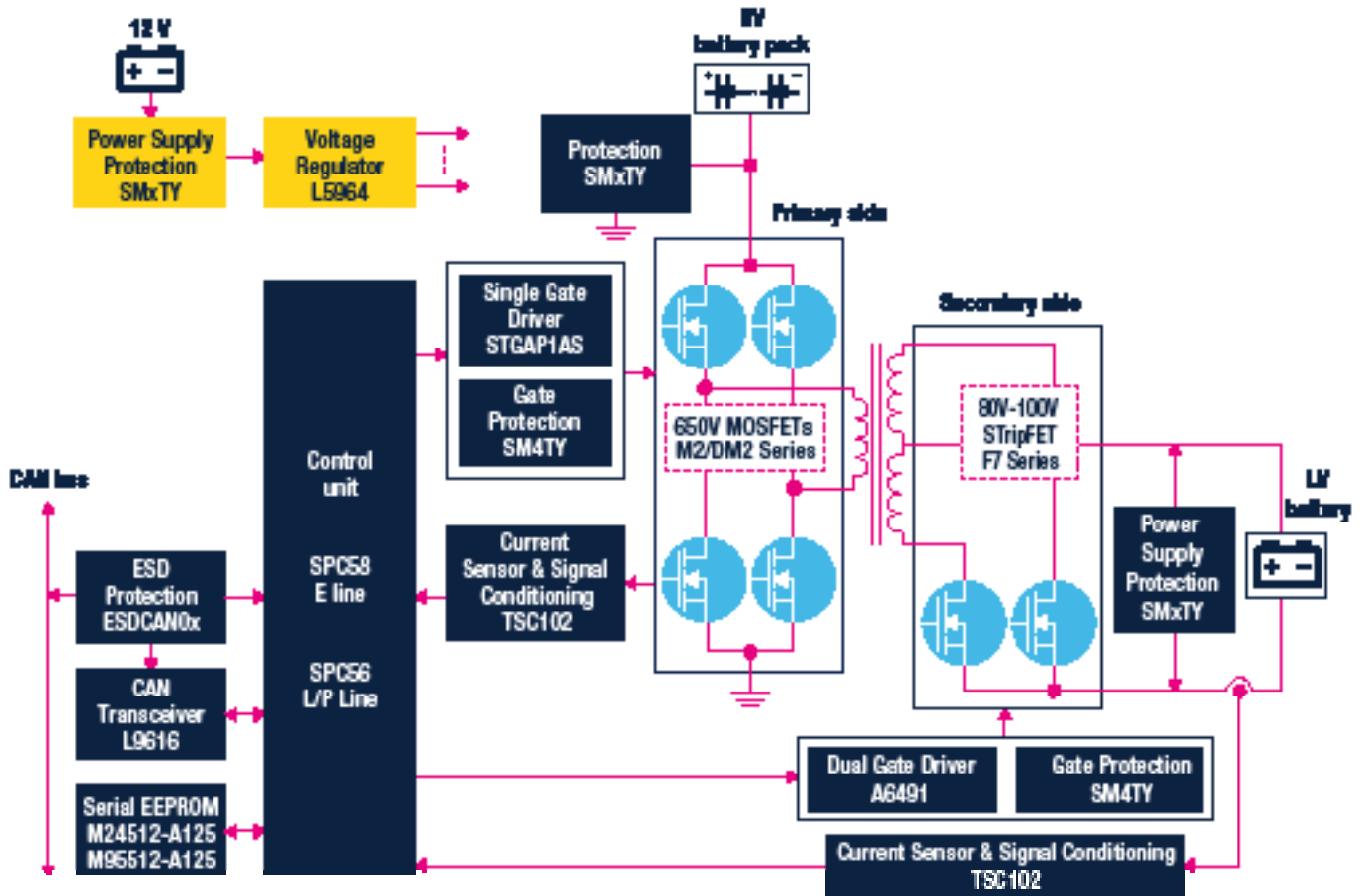

**FIND OUT MORE**

[www.st.com/bidirectional-dc/dc-converter](http://www.st.com/bidirectional-dc/dc-converter)

## BATTERY MANAGEMENT SYSTEM

Automotive Battery Management Systems (BMS) must be able to meet critical features such as voltage, temperature and current monitoring, battery state-of-charge (SoC) and cell balancing of lithium-ion (Li-ion) batteries. Indeed, the main functions of a Battery Management System for electric vehicles include:

- Battery protection in order to prevent operation outside its safe operating area
- Battery monitoring by estimating the battery pack's state-of-charge (SoC) and state-of-health (SoH) during charging and discharging
- Battery optimization thanks to cell balancing that improves the battery life and capacity, thus optimizing the driving range for hybrid (HEV), plug-in (PHEV) and full electric vehicles (BEV).

ST's Battery Management System solution for automotive applications is specifically designed to meet all these demanding requirements. Based on the new highly-integrated L9963 Battery Management IC and its L9963T isolated transceiver companion chip, our solution is able to measure up to 14 cells in series with the highest accuracy, on mono- or bi-directional daisy-chain configurations, embedding sophisticated cell monitoring and diagnostic features. It also complies with the stringent Automotive Safety Integrity Level (ASIL) D requirements.

In addition to our SPC5 32-bit automotive microcontrollers, power management ICs, system basis chips, and VIPower smart switches, ST offers a wide range of protection devices and automotive EEPROM for datalogging.

A comprehensive and flexible development ecosystem is available to help engineers find the best automotive-grade Battery Management System design for their projects.

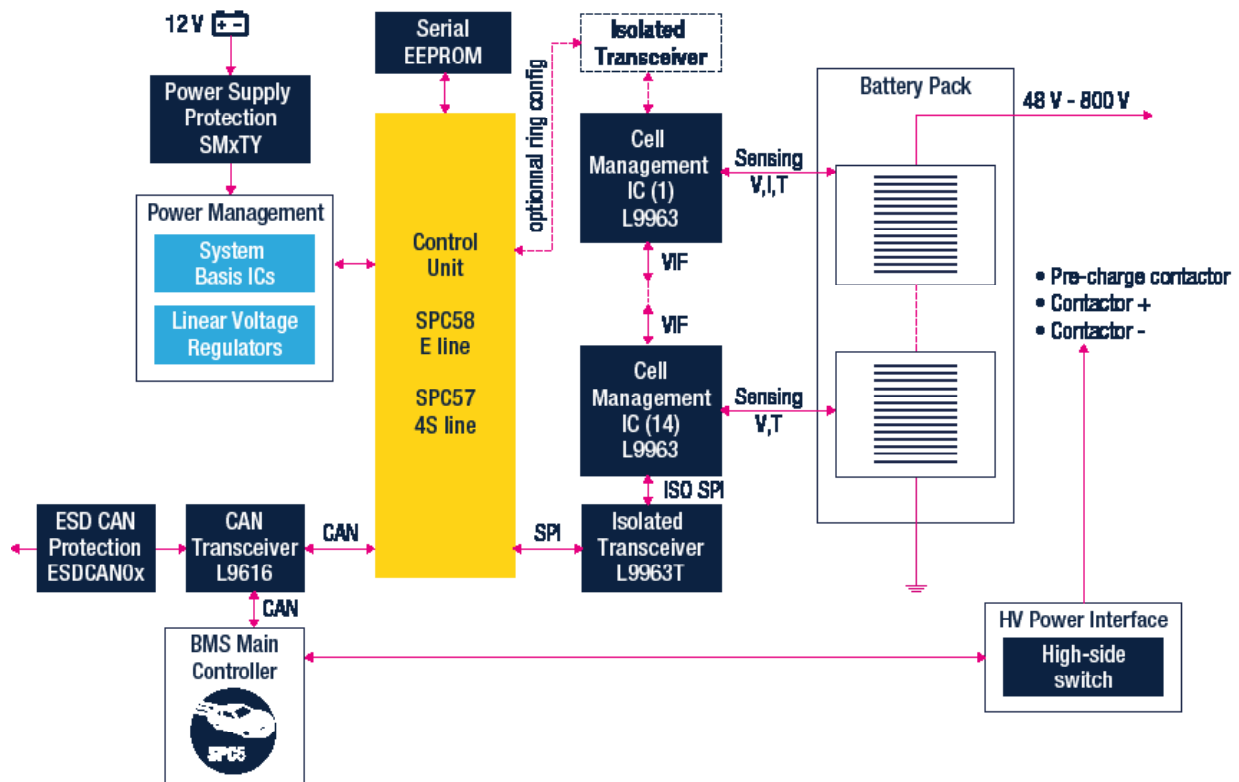

**FIND OUT MORE**

[www.st.com/auto-bms](http://www.st.com/auto-bms)

## 48V ELECTRIC TRACTION SYSTEMS

Electric traction systems for small vehicles are getting more and more popular among two- and three-wheelers ranging from pedal-assisted e-bikes to e-scooters and motorbikes. ST offers an AEC-qualified integrated chipset for the ECU (Electronic Control Unit) in electric BLDC traction motors up to 48V. The key building blocks of ST's proposal are SPC5 32-bit automotive MCU based on the Power Architecture® family, an L9907 BLDC pre-driver and 100V power MOSFETs for the bridge-inverter implementation.

Particularly suitable for motor control applications, the SPC560P automotive MCU includes specific peripherals such as 6-channel PWM outputs (FlexPWM) which can be used to control each single phase of a 3-phase BLDC motor and two ADCs whose shared signal can acquire the 3-phase current.

The L9907 is able to drive six MOSFET transistors for 3-phase BLDC motor applications. The circuit is suitable for operation in environments with a high supply voltage such as double-battery or 48V systems.

A wide selection of 100V N-channel power MOSFETs with different output currents and  $R_{DS(on)}$  according to application requirements is also part of ST's product portfolio.

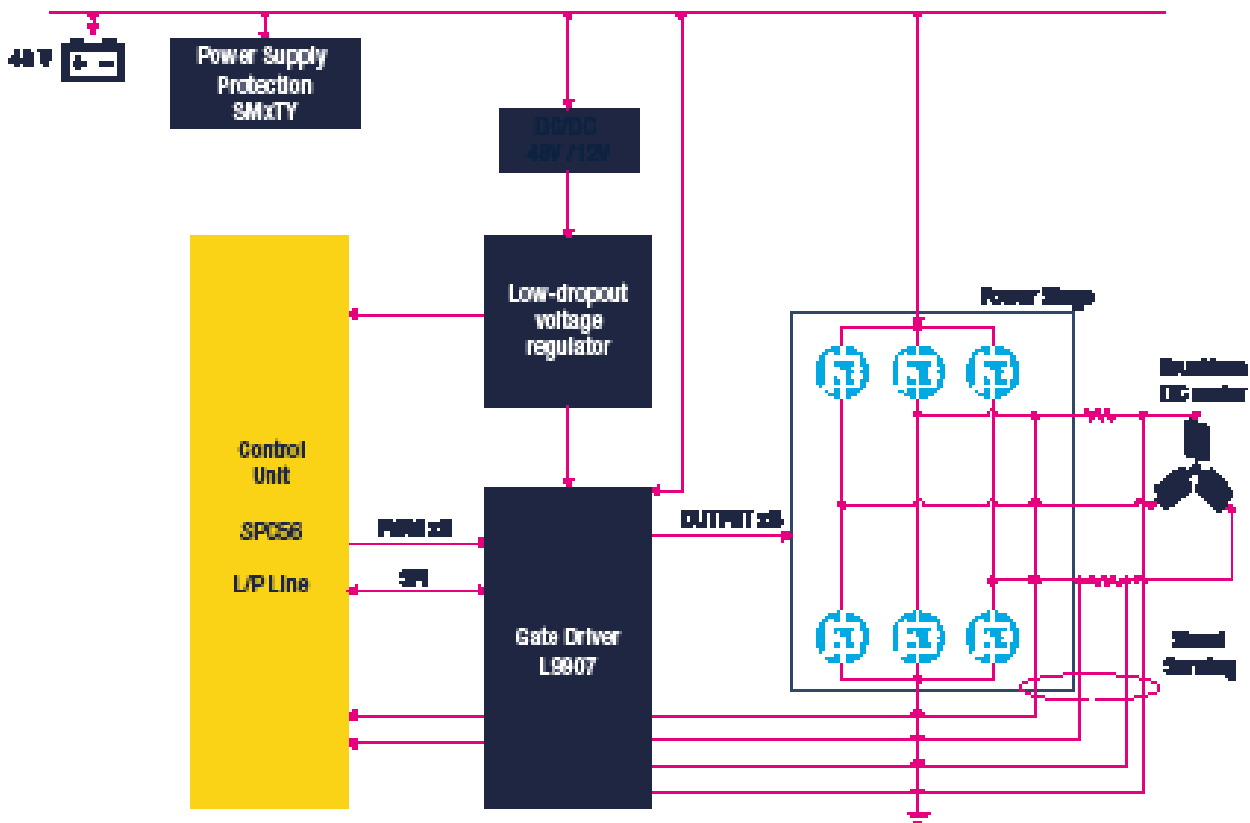

**FIND OUT MORE**

[www.st.com/48v-traction](http://www.st.com/48v-traction)

## ACOUSTIC VEHICLE ALERTING SYSTEM (AVAS)

While the benefits of electro-mobility for greener driving are very clear, it also admittedly hard to hear electric cars driving at low speeds in front of schools, at pedestrian crossings or traffic lights for instance. With the clear duty to ensure traffic safety and to protect people, especially those who are visually impaired or rely on their hearing, the automotive industry is asked to meet international requirements as comprehensively as possible, providing electric cars with an acoustic warning system.

An Acoustic Vehicle Alerting System (AVAS) is designed to emit vehicle warning sounds and alert pedestrians to the presence of electric-drive vehicles. These include hybrid (HEVs), plug-in hybrid (PHEVs), and full battery electric vehicles (BEVs) travelling at low speeds, especially in the lowest speed range above which the noise generated by rolling tires can be easily heard.

ST offers best-in-class solutions for your Acoustic Vehicle Alerting System design thanks to its Automotive Class-D audio power amplifiers, embedding diagnostics and speaker current monitoring, a power management system IC including CAN and LIN interfaces, together with an ASIL-B compliant 32-bit SPC5 microcontroller hosting the sound generation firmware.

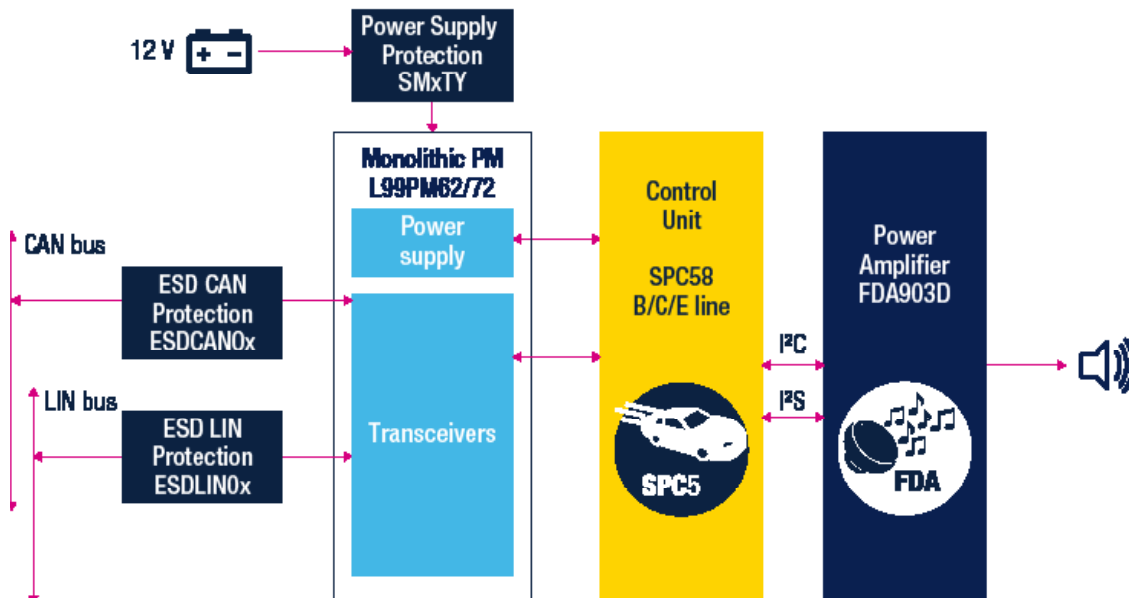

**FIND OUT MORE**

[www.st.com/avas](http://www.st.com/avas)

## HV BATTERY DISCONNECT & FIRE-OFF SYSTEM

With electric and hybrid powertrains becoming increasingly popular in both passenger cars and public transportation, additional measures are needed to ensure driver and passenger safety. As HV battery usage continues to grow, automatic systems must be available to handle specific emergencies such as a battery explosion or a fire resulting from equipment damage. Even in the event of a crash with only moderate damage, there's the concrete risk of current leaking from the HV battery into the metal chassis or frame, exposing occupants, rescue workers and first responders to potentially fatal electrical shocks. ST's dedicated passive safety solutions based on pyroswitches can activate specific countermeasures such as battery disconnects or fire extinguishers to remove or reduce the risks related to crash events involving HEV/PHEV and BEV. Our pyrotechnical safety switch system triggers controlled micro-explosions, cutting the wiring between the high-voltage battery unit and the rest of the vehicle, thus reducing or eliminating the flow of current and risk of electric shock or fire.

ST's passive safety products serve the global automotive market with several millions of parts produced annually. Our airbag systems and deployment drivers are well-established robust products with many years of proven experience in the field.

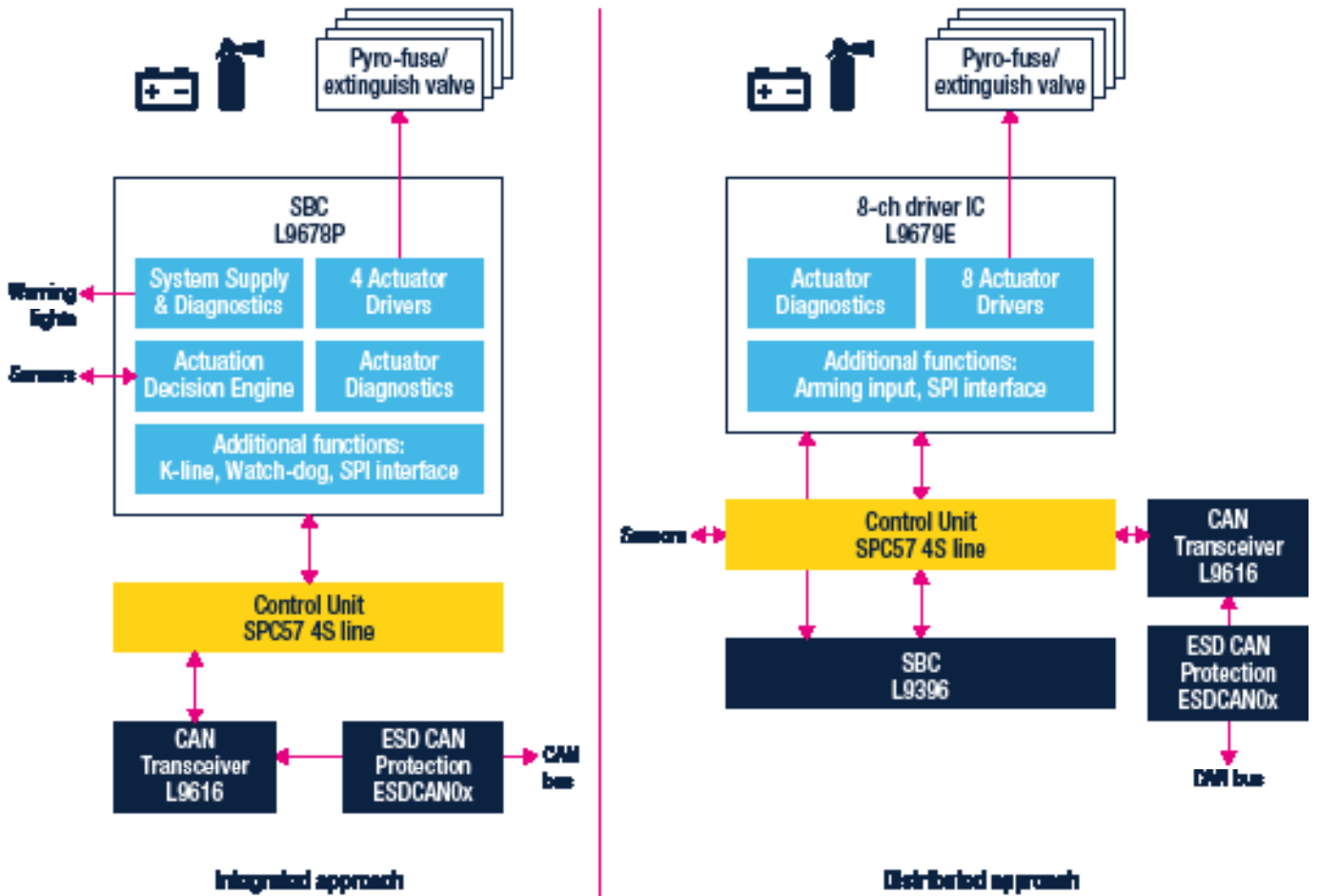

**FIND OUT MORE**

[www.st.com/battery-disconnect](http://www.st.com/battery-disconnect)

# VEHICLE CONTROL UNIT (VCU)

Vehicle electrification and new powertrain systems are driving the introduction of Vehicle Control Units (VCU) that act as domain controller for electric or hybrid vehicles. The VCU reads sensor signals from, for example, brakes, HVIL or the charger connection. Then, it acts to balance the system energy, optimize torque, control the motor, HV battery pack and the on-board charging system up to charger lock.

ST offers a complete solution for VCU applications, based on our leading-edge System Basis Chip, that brings benefits such as BOM cost savings, reduced PCB area, high integration and reliability. The offer is completed by a sensor interface, multichannel configurable HS/LS drivers and high-performance 32-bit SPC5 automotive microcontrollers with CAN transceivers and ESD protection to support your full design.

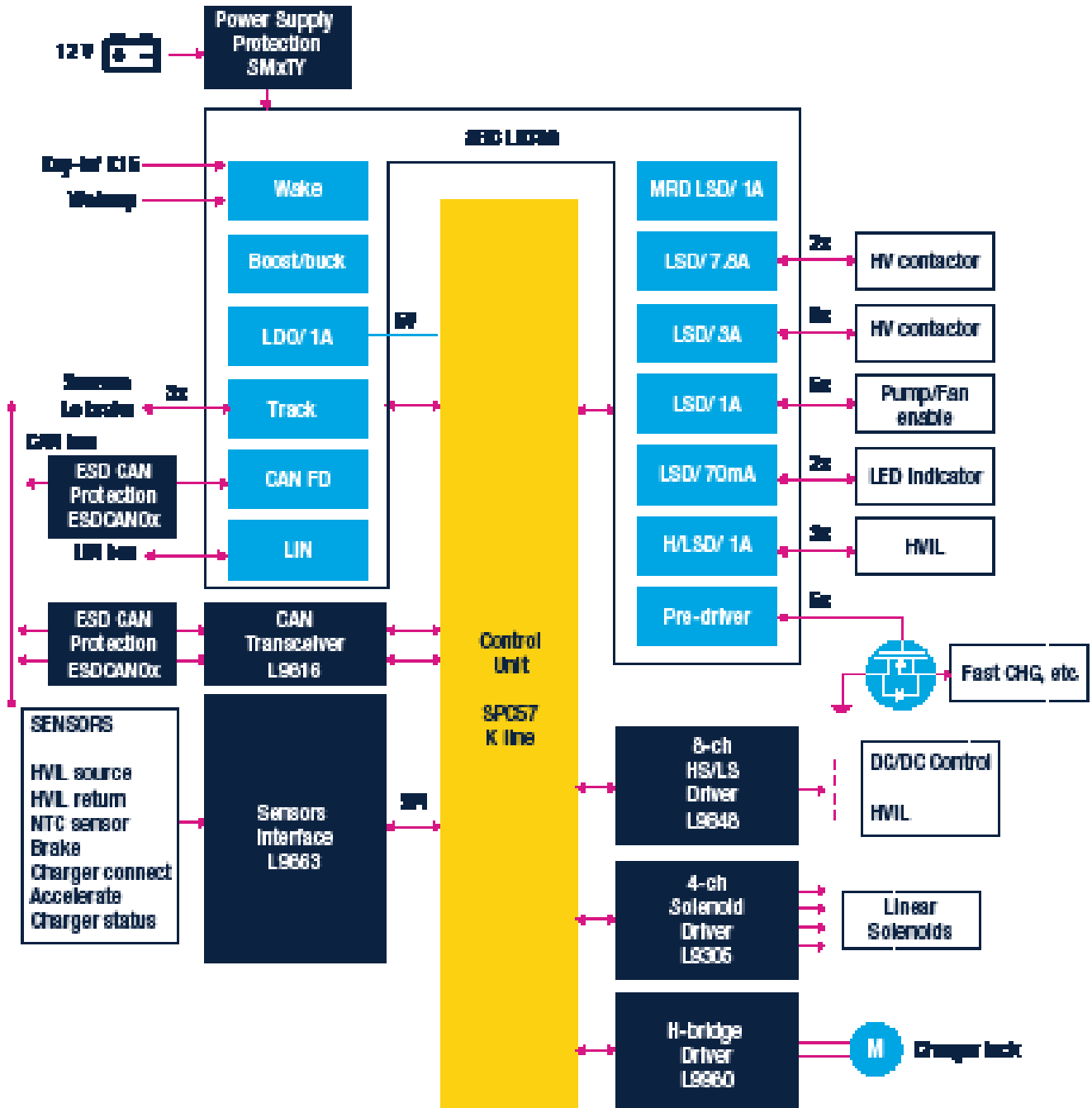

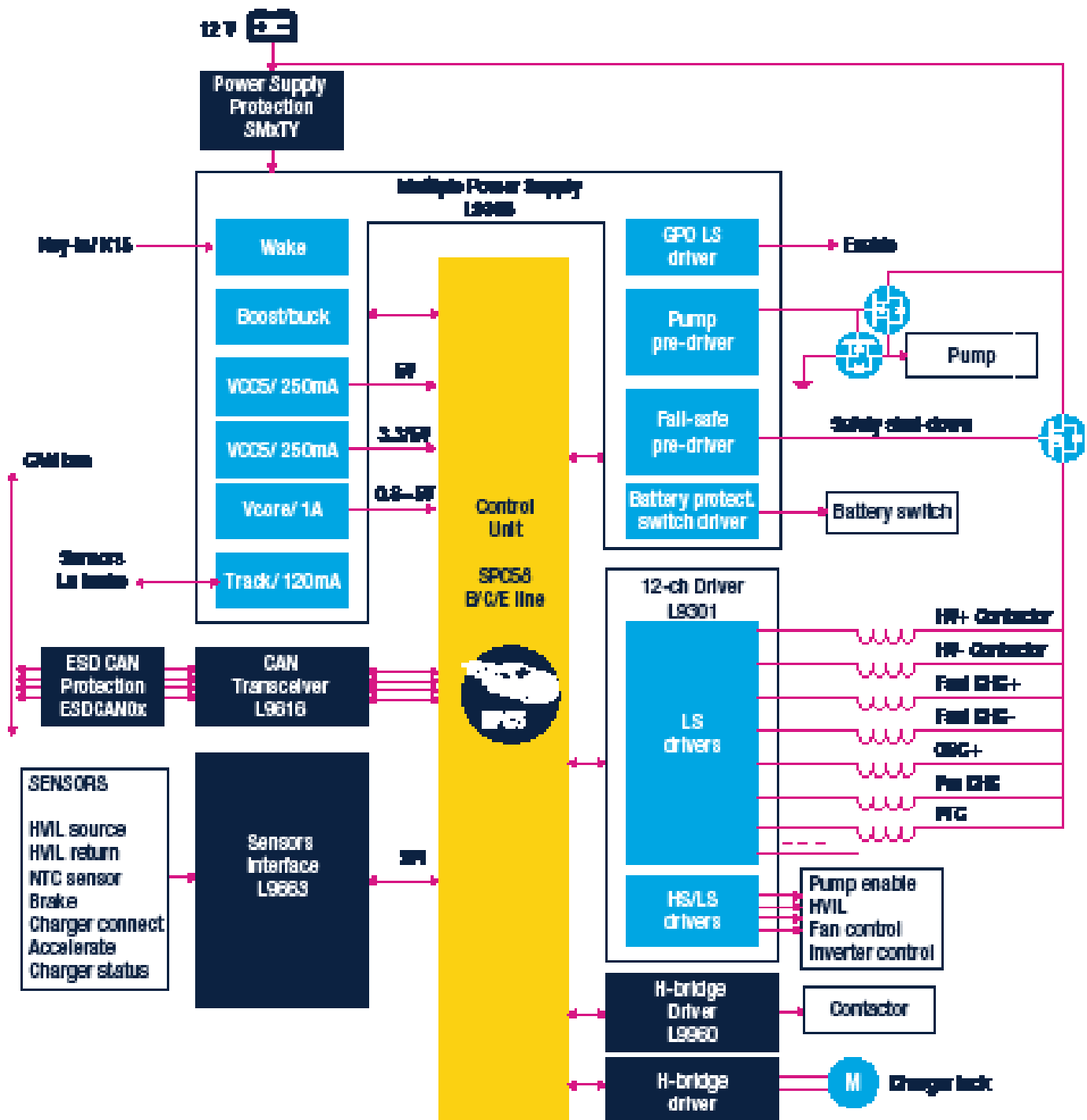

FIND OUT MORE

[www.st.com/vcu](http://www.st.com/vcu)



# Key Technologies



## RESEARCH & DEVELOPMENT AND MANUFACTURING

To keep its technology edge, ST maintains a strong commitment to innovation, with approximately 7,400 people working in R&D and product design and spending about 16% of its revenue in R&D. Among the industry's global technology leaders, ST owns and continuously refreshes a substantial patent library (~17,000 patents; ~9,500 patent families and ~500 new patent filings per year).

The Company draws on a rich pool of chip-manufacturing technologies, including advanced FD-SOI (Fully Depleted Silicon-on-Insulator) CMOS (Complementary Metal Oxide Semiconductor), differentiated Imaging technologies, RF-SOI (RF Silicon-On-Insulator), BiCMOS, BCD (Bipolar, CMOS, DMOS), Silicon Carbide, VIPower™, and MEMS technologies.

ST believes in the benefits of owning manufacturing facilities and operating them in close proximity to its R&D operations.

ST has a worldwide network of front-end (wafer fabrication) and back-end (assembly, test and packaging) plants. ST's principal wafer fabs are located in Agrate Brianza and Catania (Italy), Crolles, Rousset, and Tours (France), and in Singapore. These are complemented by assembly-and-test facilities located in China, Malaysia, Malta, Morocco, the Philippines, and Singapore.

### VIPower™

VIPower™ is a technology developed by ST and in production since 1991. Vertical Intelligent Power technologies provide control, protection and diagnostics for medium/high power automotive loads. The technology combines Vertical Double Diffused MOS Power devices with their own temperature and current sensors and CMOS and HV components for Power-Analog-Mixed design.

VIPower™ technology is the perfect choice for the control of automotive exterior and interior lighting, DC motors for seat adjustment, door locks and window lifts, resistive heaters and any kind of power load that needs control and sensing as well as power. VIPower™ products are replacing a host of electro-mechanical solutions, and providing lower power, lower chip count and lower pin-count solutions.

VIPower™ technology will play a key role in the move towards electric vehicles. The smart 48V networks used in Mild and Full Hybrid cars require intelligent power switches to drive high- and low-sided loads and electric motors, with very low losses and high current sense accuracy, all monitored via the connections to the ECUs microcontroller.



## BCD (BIPOLAR-CMOS-DMOS)

BCD (BIPOLAR-CMOS-DMOS) is a key technology for power ICs. BCD combines the strengths of three different process technologies onto a single chip: Bipolar for precise analog functions, CMOS (Complementary Metal Oxide Semiconductor) for digital design and DMOS (Double Diffused Metal Oxide Semiconductor) for power and high-voltage elements.

This combination of technologies brings many advantages: improved reliability, reduced electromagnetic interference and smaller chip area.

BCD has been widely adopted and continuously improved to address a broad range of products and applications in the fields of power management, analog data acquisition and power actuators. For EV charging BCD is ideal for battery management systems.

## 1200V AEC-Q101 qualified technologies for EV charging

High voltage rectifier and thyristor technologies are the keys to develop robust, immune AC line connected systems exhibiting high power density. ST has developed a set of automotive grade technologies for full rectification functions in the low frequency (AC line) or high frequency ranges (DC-DC conversion). AEC Q101 qualified, these rectifier diode and thyristor series are available to design robust converters compatible with the most stringent electromagnetic norms such as burst or surge voltages.

## TRANSIL™

TRANSIL™ is a key planar technology for Automotive TVS series designed to protect automotive sensitive circuits against surges as defined in ISO 7637-2 and ISO 16750 tests A and B also called load-dump (battery lines), ISO7637-3 (data lines) and ESD as defined in ISO 10605. Protection is also provided against other perturbations generated by elements like ignition, relay contacts, alternators, injectors, SMPS, etc.

This technology is compatible with high-end circuits where low leakage current and high junction temperatures are required to provide reliability and stability over time.

## STPOWER

Leading-edge power technologies for both high- and low-voltage applications combined with a full package range and innovative die bonding technologies exemplify ST's innovation in power transistors of the STPOWER™ family.

ST offers a wide portfolio of power MOSFETs ranging from -100 to 1700V, IGBTs with breakdown voltages ranging from 300 to 1250V and power bipolar transistors ranging from 15 to 1700V. Improved thermal design of ST's power electronics systems, and our silicon-carbide (SiC) MOSFETs ensure automotive robustness with the industry's highest temperature rating of 200 °C.

Our extensive STPOWER™ product portfolio combined with state-of-the-art packaging and protection solutions enable designers to create products with high reliability, efficiency and safety.



# Development Tools

## PRODUCT SELECTORS, SAMPLES, EVALUATION BOARDS

ST provides a set of Smart Selectors tuned to the needs of the Automotive Industry. Once the appropriate products have been selected, a wide range of samples and evaluation boards are available to help you get started and reduce your development times. In addition to boards, ST provides schematics, BOM and Gerber files to facilitate your hardware design and demonstration software packages are available too.

### VIpower™ Smart Selector

VIpower's Smart Selector is designed to help and assist users to choose the best VIpower™ high/low-side switch or H-bridge device for their Automotive application.

All you need to do is select a few parameters related to your specific application, and the selector provides the relevant device. Parameters include nominal voltage (12V for automotive cars or 24V for trucks), a topology (high-side, low-side or h-bridge), the number of channels and type of load to drive (bulbs, motors, etc.). The selection can be further refined by setting source type (DC or PWM), temperature and PCB type.



**FIND OUT MORE**

[www.st.com/vipower-smartselector](http://www.st.com/vipower-smartselector)

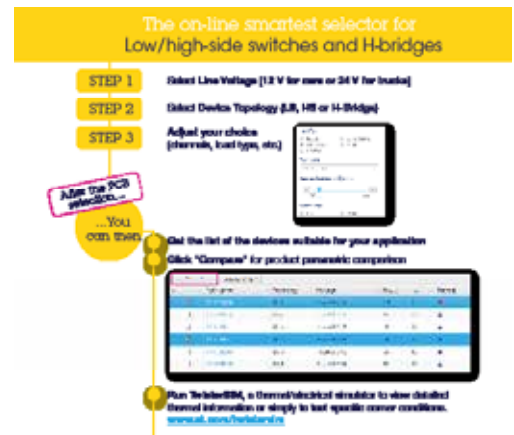

### VIpower-FINDER

VIpower-FINDER is the application available for Android™ and iOS™ that allows you to explore the ST VIpower product portfolio using portable devices.

You can easily define the device that best fits your application using the smart or the parametric search engine. You can also find your product thanks to the efficient part number search engine.

#### Key Features

- Smart, parametric or part number search capability for product
- Technical datasheet downloading and off-line consulting
- Ability to share technical documentation via social media or via email.



**FIND OUT MORE**

[www.st.com/vipower-finder](http://www.st.com/vipower-finder)



## Easyboards

The Easyboard concept was created to give customers the chance to evaluate products without committing to the expense, time and resources typically needed to design a custom circuit board. Easyboards are simple and low-cost evaluation tools that connect a VIPower™ product to a load. This allows a straightforward evaluation of the device and of all the application functionalities, including the auto-protection capability for hazardous conditions. Each evaluation board includes a VIPower™ device soldered onto a small 2-layer PCB with heavy copper and thermal vias, to support maximum device current and customer-configured thermal relief strategies.

Easyboards come with the following part numbers:

- EV-VNx7xxx: VIPower M0-7 High Side Switches single, dual and quad channels for 12 V battery lines
- EV-VNx5Txxx: High Side Switches for 24V systems
- EV-VNH7xxx: Motor Control solutions



L99LD21-ADIS



SPC560B-DIS



### FIND OUT MORE

[www.st.com/automotive-evalboards](http://www.st.com/automotive-evalboards)

## Dynamic Electro-Thermal simulator for devices in VIPower technology

TwisterSIM is a unique electro-thermal simulator that helps shorten the design solution cycle by enabling, in a few clicks, complex engineering evaluations with accurate simulations like load compatibility, wiring harness optimization, fault condition impact analysis, diagnostic behavior analysis and dynamic thermal performance.

A built-in interactive selector provides a short list of suitable devices based on first level system requirements. It assists you in detailing your actual system configuration with layout, load and driving profile customization to build an accurate model of the final application.

TwisterSIM supports a large selection of Low/High-side driver/switches and H-bridges for Motor Control.



### FIND OUT MORE

[www.st.com/twistersim](http://www.st.com/twistersim)

## SPC5 AUTOMOTIVE MCU EVALUATION TOOLS: EASIER EVALUATION AND FASTER DEVELOPMENT

A complete range of hardware evaluation and emulation tools supports the SPC5 family of automotive microcontrollers. Discovery and Premium development boards are available to support your development from preliminary evaluation to advanced solution development.

ST Discovery boards, available for each product line, enable a quick and easy way to evaluate the microcontroller's main features. The expansion connector makes it easy to plug-in application and extension modules for rapid prototyping.

ST Premium boards, available for all lines and packages, provide user access to the device's complete feature set and functionalities for advanced development. The SPC5 motherboards, used in combination with adapters, enable full access to all of the MCU's signals and peripherals (such as CAN, SPI, LIN, FlexRAY and Ethernet).

The offer is complemented by a series of emulation solutions for high-speed tracing, monitoring and bypassing.

A full range of state-of-the-art tools and software from major third parties are also available for the SPC5 family.



The infographic features a central blue circle with a white car icon and the text "SPC5" and "SPC5 MCUs toolchain". To the right, four white boxes with blue borders and icons describe the toolchain components:

- Discovery kits** (circuit board icon): Quick starter kit for early evaluation. ST Discovery boards enable the user for a quick evaluation of main device features.
- Premium boards** (circuit board icon): Complete HW solutions for advanced development. ST Premium boards ensure full access to device's features and functionalities.
- SPC5Studio** (Eclipse IDE icon): Freeware Eclipse based Development Studio. SPC5Studio integrates our Resources Configurator, Code Generator supporting major third party tools.
- Embedded Software & AUTOSAR Solutions** (car icon): Drivers and Software Libraries. Crypto and flash SW Libraries. Core & Instruction Self test Libraries. AUTOSAR MCAL.



**FIND OUT MORE**

[www.st.com/auto-sp5-mcu-evaltools](http://www.st.com/auto-sp5-mcu-evaltools)



## AUTODEVKIT™

A viable, simple, low-cost tool for automotive application engineers

A new development flow and toolset dedicated to the Automotive & Transportation market delivering to engineers the best and easiest way for quick evaluation and rapid prototyping in a common, integrated and flexible environment supporting complete ECU-like development.

AutoDevKit is an Eclipse plug-in running under SPC5Studio Integrated Development Environment.



AEK MCU Discovery  
and Functional  
Boards

### KEY FEATURES

- Focus in developing your application without bothering about hardware and software implementation details
- Assemble and re-assemble hardware and software components without compatibility issues
- Expand and customize your application adding new components, scaling your microcontroller for cost optimization, changing the compiler, adding a real-time operating system and other Eclipse-compatible plug-ins

AEKD System  
Solution  
Demonstrators

STSW Embedded  
Software

### FIND OUT MORE

Find out more at [www.st.com/autodevkit](http://www.st.com/autodevkit)

Software download [www.st.com/autodevkitsw](http://www.st.com/autodevkitsw)

Join our Community at <https://community.st.com/autodevkit>



**At STMicroelectronics  
we create technology  
that starts with You**





# life.augmented



Order code: BRAUTOEM0920

For more information on ST products and solutions, visit [www.st.com](http://www.st.com)

© STMicroelectronics - September 2020 - Printed in the United Kingdom - All rights reserved  
ST and the ST logo are registered and/or unregistered trademarks of STMicroelectronics International NV or its affiliates in the EU and/or elsewhere. In particular, ST and the ST logo are Registered in the US Patent and Trademark Office. For additional information about ST trademarks, please refer to [www.st.com/trademarks](http://www.st.com/trademarks).  
All other product or service names are the property of their respective owners.

